

FUNDAMENTALS OF GAS TURBINE METERS

Paul Honchar
Sr. Product Manager
Sensus
805 Liberty Boulevard
DuBois, PA, USA 15801

Introduction

The majority of all gas measurement used in the world today is performed by two basic types of meters, positive displacement and inferential. Positive displacement meters, consisting mainly of diaphragm and rotary style devices, generally account for lower volume measurement. Orifice, ultrasonic and turbine meters are the three main inferential class meters used for large volume measurement today. Turbines are typically considered to be a repeatable device used for accurate measurement over large and varying pressures and flow rates. They are found in a wide array of elevated pressure applications ranging from atmospheric conditions to 1440 psig. Turbine meters have also become established as master or reference meters used in secondary calibration systems such as transfer provers. A significant number of both mechanical and electrical outputs and configurations have become available over the past 60 years of production.

This paper will focus on the basic theory, operating principles, performance characteristics and installation requirements used in turbine meter applications. A discussion of fundamental turbine meter terminology is also included.

Theory

An inferential style device derives or “infers” volumetric measurement using the concept of velocity. In the case of the turbine meter, the flowing gas velocity is represented by the rotation of the rotor itself. The speed or rotation of the rotor is directly proportional to the rate of flowing gas.

Flowing gas enters the inlet of the turbine meter and is immediately directed through a smaller channel created by the annular passage between the body and nose cone (Illustration 1).

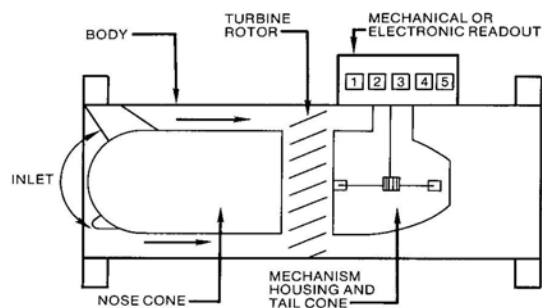

Illustration 1

The purpose of the nose cone is to straighten and condition the flowing gas as well as provide a desirable velocity flow profile. This internal inlet configuration effectively reduces the cross-sectional area of the body, thus increasing the velocity of the flowing gas.

Increasing the velocity of the flowing gas is critical to a turbine's performance as the kinetic energy also increases proportionally. By definition, kinetic energy is the physical energy of mass in motion. More importantly, kinetic energy is the driving force behind the operation of a turbine style device. This fundamental can be represented by the following equation:

$$KE = \frac{1}{2} MV^2$$

Where:

KE = kinetic energy (driving force)

M = mass (pressure)

V = velocity (flow rate)

It can be seen that increasing either the flow rate (velocity) or pressure (mass) of the gas will also increase the available kinetic energy. Thus, the annular channel created by the nose cone will increase the flowing gas velocity and magnify the amount of kinetic energy. Also, an increase in the flowing gas velocity will have a more significant effect than an increase in the gas pressure as the velocity factor is squared in this equation.

Kinetic energy or driving force is the concept that allows the meter to overcome the adverse effects of friction. As with most mechanical devices, frictional forces tend to slow the basic operation of the apparatus, causing a loss of registration. The measurement inaccuracies caused by friction are especially prevalent at low flow rates and/or low operating pressures.

There are two types of friction; mechanical and fluid. Fluid friction is a resultant of the flowing gas molecules crossing the surface of the turbine meter impeller and adjacent passageways. In addition, fluid friction is a function of the flowing gas characteristics and internal turbine meter design, making it difficult to control.

On the other hand, mechanical friction is created by the natural interaction of moving parts. Mechanically driven indexes, volume correctors, gearing and couplings constitute the majority of this principle. Excessive mechanical friction can result in the loss of registration, binding, and possible damages to internal components in severe cases. It is important to take precautions in eliminating friction through proper sizing and installation as well as following the manufacturers recommended procedures for maintenance and lubrication.

Principles of Operation

Illustration 2 shows the cross-sectional view of a top entry style turbine meter. This model provides a better explanation of the basic principles of operation.

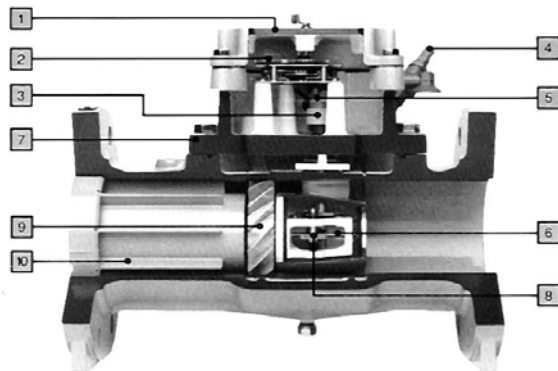

Illustration 2

The flowing gas will encounter the angular blades of the rotor or impeller immediately after leaving the channel created by the nose cone, as shown in item 10.

The turbine rotor, as shown by item 9, generally features a blade angle of either 30° or 45°, depending upon the model. A lesser blade angle will result in a larger capacity rating because of the degree at which the flowing gas strikes the rotor blades. For example, at identical flow rates, the 30° rotor will operate at a lesser rpm than the 45° counterpart. Thus, the 30° model can be operated at a considerably higher flow rate without suffering from physical damages or decreased service life. A 30° rotor (left) and 45° rotor (right) are shown in illustration 3.



Illustration 3

The rotor is mounted on a shaft (item 6) which is generally supported by two lubricated bearings. Note that the external lubrication system for this turbine is shown by item 4. This horizontal shaft in turn drives a vertical shaft using a set of internal gears (item 8). This shaft is also supported by two bearings, however, these bearings are usually of a sealed design and generally do not require lubrication.

The vertical shaft is linked to the magnetic coupling (item 3). The magnetic coupling is unique in that it allows the turbine meter to overcome a basic but difficult problem; transferring the mechanical motion or energy of the turning rotor from the pressurized to the non-pressurized area. Once accomplished, this mechanical output is now transformed into a useable form of registration.

The gear train (item 2) converts the mechanical motion created by the turning rotor into a more useful format. The desired mechanical output is generally in standard incremented units such as 1, 10, 100 or 1000 cubic feet per revolution (0.1, 1 or 10 cubic meters per revolution metric equivalent), thus allowing it to easily communicate to a manually read index, pulsing device or volume corrector. The link provided between the gear train and totalizing device is commonly referred to as an index plate or instrument mounting plate (item 1).

A secondary function of the gear train is to provide a base on which the timing gears or change gears may be mounted. These two gears allow the turbine's calibration accuracy to be shifted in a linear fashion. These gears are especially critical during the initial calibration procedure and should be re-established after any activity that may effect the accuracy of the meter.

A large variety of low frequency and high frequency electrical pulse outputs are also offered on the turbine meters found in industry today. These outputs may be found in both the pressurized and non-pressurized areas of the turbine meter.

End-entry turbines, another popular option, require the removal of the meter body from the pipeline to fully access the measuring module or cartridge.

Terminology

Turbine accuracy is shown as a comparison of the volume measured by the meter to the true or absolute volume passing through the meter during a specified period of time. This accuracy is expressed as a percentage represented by the following formula:

$$\% \text{ accuracy} = \frac{\text{meter volume}}{\text{true volume}} \times 100$$

A reference or standard or master meter, determines the absolute or true volume. The accuracy of a turbine meter is application specific and generally accepted to be +/- 1.0% in the North American industry today. This accuracy can often be improved when the meter is calibrated under more defined conditions, such as elevated pressures or specific flow rates.

A turbine's maximum rated capacity (Q_{max}) is listed as the maximum flow rate a particular model can accommodate without sacrifice to the life expectancy of the meter. Q_{max} represents a certain rotor speed or rpm that should not be exceeded for extended periods of time. At elevated pressures, the maximum capacity in scfh increases directly as does the Boyle's Law pressure multiplier factor. When expressed in acfh, line rate, or dial rate, Q_{max} will not change at elevated pressures because the pressure multiplier is not a factor.

The minimum rated capacity (Q_{min}) for a turbine is generally considered to be the lowest flow rate at which the meter can still maintain an accuracy of +/- 1.0%. A decrease in kinetic energy, attributed to low flow velocities, will allow frictional forces to act upon the turbine causing it to run slow or under-register. However, this loss of flow rate is partially compensated for by an increase in line pressure. Therefore, at elevated pressures the minimum capacity in scfh increases directly as does the square root of Boyle's Law pressure multiplier. For this reason, the term Q_{min} , when expressed in acfh, becomes noticeably improved at elevated operating pressures.

The rangeability or turndown of a turbine meter is simply denoted as Q_{max} / Q_{min} for that model. This value represents the entire operating range of flow rates at which a turbine will maintain a specified performance accuracy. The rangeability of a turbine meter improves at elevated pressure due to the increase in gas density and subsequent improvement in the rated Q_{min} . A turbine's rating is usually listed at atmospheric conditions for reasons of comparison and may exceed 200:1 at increased pressure applications as shown in illustration 4.

MARK II 4" T-18 TURBO-METERS TYPICAL PERFORMANCE DATA

U.S. Units=Cubic Feet

Compressibility Ratio $s=(P/P_0)^2$	Meter Pressure PSIG	Maximum Flow Rate SCFH	Maximum Flow Rate MSCFD	Minimum Flow Rate SCFH	Minimum Flow Rate MSCFD	Minimum Dial Rate ACFH	Maximum/Minimum Flow Range	Approximate Pressure Loss Inches W.C.
1.0000	0.25	18,000	430	1,200	29	1,200	15	1.8
1.0008	5	24,000	580	1,400	34	1,040	17	2.4
1.0016	10	30,000	720	1,500	36	930	20	3.0
1.0024	15	36,000	860	1,700	41	850	21	3.6
1.0032	20	42,000	1,010	1,800	43	780	23	4.2
1.0040	25	48,000	1,150	2,000	48	730	24	4.8
1.0080	50	79,000	1,900	2,500	60	570	32	7.9
1.0121	75	111,000	2,660	3,000	72	480	37	11
1.0162	100	142,000	3,410	3,400	82	430	42	14

Illustration 4

The term repeatability refers to a meter's ability to duplicate measurement results when multiple tests are performed at similar conditions. Many turbine manufacturers supply repeatability information for both the mechanical and electronic outputs of that model. Repeatability data should represent the meter only, and any errors or uncertainties associated with the calibration system should be ignored. The physical condition of a turbine meter plays a critical role when evaluating repeatability over an extended period of time.

The pressure loss in a pipeline caused by a turbine meter, also referred to as the pressure drop across the meter, can be attributed to the energy expended to compensate for frictional and driving forces. Frictional forces include fluid friction, while driving force is necessary to operate the mechanics of the meter. Pressure drop is measured between one point upstream of the meter and one downstream. Turbine manufacturers generally provide pressure loss information at both atmospheric and elevated pressure conditions. The rating is usually listed at Q_{max} for that model under those conditions (illustration 4).

The module interchangeability for a turbine represents the change in performance accuracy seen when installing a specific module or cartridge into an infinite number of bodies. This factor is an important consideration for field upgrades when determining the need for a complete meter versus simply changing the measuring cartridge. In addition, the interchangeability factor should be examined when deciding to remove the complete meter or cartridge only from the field for repair, service and re-calibration. Module interchangeabilities for turbine meters today generally range between +/- 0.1% to +/- 0.5% depending upon the model, vintage and technology.

Approximately 30 years ago the dual rotor turbine meter was introduced into the industry. This model features a secondary rotor used to provide full or partial compensation for measurement inaccuracies attributed to the first or primary rotor. In general terms, the first rotor still maintains a mechanical output used to drive a direct reading index, volume corrector or pulse emitting device. This mechanical volume is similar to that of any single rotor turbine in that it performs no correction for measurement errors, such as non-uniform flow profiles or typical meter problems (bearing wear, mechanical friction, component damage, contamination, etc).

The two rotors are mounted upon separate shafts, which in turn are supported by bearings. The turbine meter lubrication system will supply oil to both sets of bearings during each lubrication procedure.

Illustration 5 shows the secondary rotor that is located immediately downstream of the primary rotor. Note that the blade angle of the secondary rotor is much smaller than the primary main rotor. Thus the secondary rotor turns at approximately one tenth of the main rotor's speed.

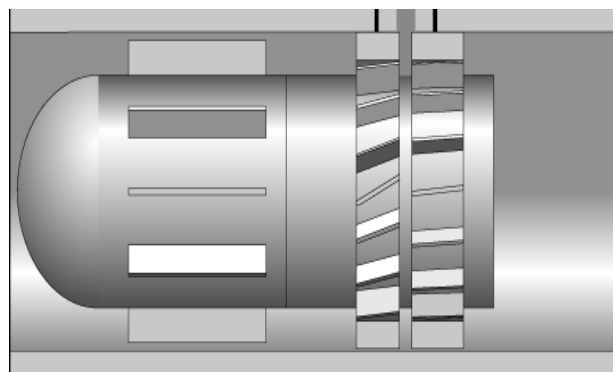

Illustration 5

The secondary rotor is driven by the exit angle of the gas as it leaves the trailing edge of the primary rotor. The speed relationship between these two rotors will allow the secondary rotor to provide an adjustment to the volume measured by the first rotor. This compensation is performed through calculations done by preset formulas unique to the model used.

In addition to this self-correcting feature, the dual rotor turbine also provides a form of in-line calibration. By examining any change in the rpm relationship between the two rotors, the technician can compare the adjusted output to that of the original factory calibration. The original factory calibration was performed under ideal conditions, thus creating a baseline analysis for all future checkpoints. This has become a useful tool in both troubleshooting the meter as well as the surrounding piping configuration.

The adjusted output and calibration features produced by the turbine are a product of the electronic signals emitted by both rotors. To utilize the benefits of a dual rotor turbine a specialized instrument or preprogrammed flow computer is required.

Installation

The surrounding piping configuration will have an effect on most inferential measurement devices. As velocity sensing meters, gas turbines are no exception.

The American Gas Association has provided the optimum or recommended installation in Report No. 7. This arrangement consists of ten pipe diameters of straight pipe immediately upstream of the meter and five pipe

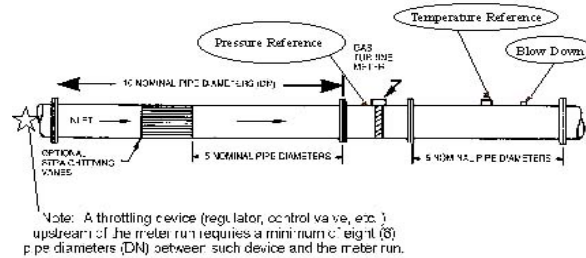

RECOMMENDED INSTALLATION OF AN IN-LINE GAS TURBINE METER (MINIMUM LENGTHS)

diameters downstream (illustration 6).

Illustration 6

An additional eight pipe diameters is recommended to the upstream piping if any type of throttling device such as a valve, filter or regulator is installed upstream of the turbine. This report specifies that all pipes specified must be the same diameter as the turbine itself. The optional upstream straightening vanes or tube bundles are recommended for any turbine that does not feature some type of built-in flow conditioning device. A common example of such an internal device is a nosecone assembly with integral straightening vanes or fins. Also noted in this report are precise locations for blow down taps, pressure reference ports and temperature reference ports.

A second piping set-up, known as the short coupled installation, is often used when there are limitations to the amount of space available (illustration 7).

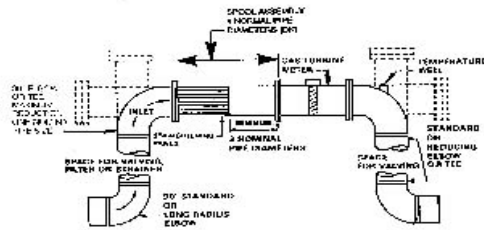

SHORT COUPLED INSTALLATION OF AN IN-LINE GAS TURBINE METER (MINIMUM LENGTHS)

6

Illustration 7

This less desirable configuration may also become attractive when retrofitting a turbine meter as a replacement for another type of measurement. This arrangement consists of an elbow or tee immediately followed by four pipe diameters of straight pipe and the meter. The turbine meter outlet connects into another elbow or tee without any straight run of pipe. For this scenario any potentially throttling device is installed upstream of the first elbow or tee and straightening vanes are used in the short upstream pie. Straightening vanes are inserted at the mouth of the inlet piece or two pipe diameters from the turbine inlet. The 90 degree turn found in the first elbow or tee acts as a dampener for pulsation, jetting and other non-uniform flow profiles. The use of straightening vanes provides additional flow conditioning when negative or positive swirling is present.

A third arrangement listed by the AGA Report No. 7 is the close coupled set-up (illustration 8). This simpler configuration consists of an elbow or tee followed by the meter and then another elbow or tee located at the turbine outlet. No runs of straight pie or straightening vanes are used. Once again, any throttling device is positioned upstream of the first elbow or tee along with the required filters or strainers.

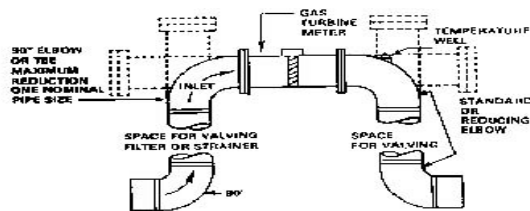

CLOSE COUPLED INSTALLATION OF AN IN-LINE GAS TURBINE METER WITH INTEGRAL STRAIGHTENING VANES

8

Illustration 8

While this installation is less expensive and compact, it may have adverse effects on the accuracy of the turbine and should only be considered when it is the only option available. Turbine meters without built-in integral straightening vanes or conditioners should not be used for this arrangement.

The makers of most turbines base the meter performance accuracy on testing conducted in the recommended or ideal piping set-up. Some manufacturers will supply additional performance data for a meter installed in the short couple or close couple configuration. The International Standard ISO 9951 has developed a high level perturbation test to simulate both of these piping arrangements.

Unwanted in-line debris is always a source of concern. Weld slag, rust scale, liquid slugs and other contaminants often cause costly damages to measurement devices. The manufacturer of the turbine meter should be consulted for any specifications regarding the upstream installation of strainers and filters. It is important to remember that these devices must be properly maintained, as they may become a source of the problem rather than the solution if dirty, damaged or incorrectly installed.

Most turbine meters available today can be mounted in either the vertical or horizontal position without compromise to the meter performance or life expectancy. Special considerations may be required for proper lubrication when mounting the unit in a vertical orientation.

An installation prone to operating at flow rates greater than the meters rated capacity may utilize a flow limiting orifice or sonic venturi nozzle installed downstream of the meter. The purpose of these devices is to provide an in-line restriction that limits the flow rate to approximately 120% of that models capacity rating.

Today's turbine meters are predominately uni-directional by design, however bi-directional versions are available. Special valving is required to assure that damages attributed to reverse flow are not introduced to turbines not recommended for bi-directional flow.

With proper installation, straightening vanes or tube bundles are designed to eliminate both negative and positive swirls prior to entering the turbine meter inlet. These swirling conditions are a resultant of valves, fittings, elbows, tees and regulation found upstream of the turbine. The location and design of this device is critical, and should be determined as per AGA Report No. 7 recommendations.

Maintenance

As with most mechanical devices turbine meter bearings require lubrication; with the exception of ceramic or sealed bearings used for special applications. The three most common methods of turbine lubrication are gravity feed, pressurized pump guns and automatic oilers. The simplest technique, gravity feeding, requires no equipment as the recommended oil is fed into the external lubrication valve directly from the bottle. The pressure feed requires the use of a pump gun capable of containing full line pressure. This method is often preferred as the gun pushes new oil into the rotating bearings as the old, contaminated oil is flushed outward. The third method utilizes an automatic lubricating device. This method dispenses a preset volume of lubricating oil into a turbine based on time increments or volume measured. While more costly, this approach has become popular for remote locations where manpower and time is at a premium.

By conducting a spin test the technician can determine if excessive levels of mechanical friction are acting upon the turbine. High levels of friction may result in mechanical binds, loss of registration, or a catastrophic failure under severe conditions. The spin test provides a useful tool in establishing both lubrication schedules as well as a frequency for module removal and service.

Although a critical part of routine turbine maintenance, it is important not to substitute the spin test for other pertinent procedures. These additional efforts include the visual inspection and periodic re-calibration. The operator must bear in mind that it is possible for a turbine to achieve an acceptable spin test while being grossly out of calibration. For example, installing the wrong timing gears on a meter may effect the performance accuracy by several percent, however this meter may still pass a spin test. Although rare, it is feasible that a rotor missing one or more blades could also pass this procedure. Thus, the spin test should be considered only one integral part of a turbine meter maintenance program.

Conclusion

Turbine meters were introduced to the natural gas marketplace over 60 years ago. The turbine meter of today offers a reliable and repeatable form of gas measurement. A wide variety of both mechanical and electrical readouts, coupled with low pressure drop and good rangeability, make this form of measurement a popular one. Dual rotor turbines have added to this attraction by creating a turbine that provides compensation to typical mechanical problems as well as undesirable flowing gas conditions. As with most inferential measurement devices, care should be taken to create a piping configuration indicative of a uniform flow profile. Proper sizing, installation and maintenance procedures are critical in maintaining the desired performance and longevity of these devices.